

CENTOR TRAFFIC BARRIER

Product Code: CP72CENTOR

INSTALLATION MANUAL

Latest Revision: 03.10.2006
Document Ref.: 1123.D.01.0002_7



CENTURION
THE AUTOMATIC CHOICE

Table of Contents

Introduction	2
Basic Kit	2
Recommended Tools	3
Types of Booms - Simplex / Complex	4
Determination of Operational Mode	5
Orientation	6
Cable Requirements - Simplex / Complex	7
Counter Balance Spring Selection	9
Installation	10
Positioning	10
Bolting Down Arrangement	10
Converting Orientations	12
Correct Boom Coupler Crank Arm Alignment in Boom Lowered Position	14
Boom Pole Assembly	15
Counter Balance Spring Selection	18
Electrical Connections	19
Simplex	20
Mains Supply	20
Trigger Input	21
Safety Beam	21
Courtesy Light	22
Complex	22
Mains Supply	22
Memory Input (MI)	22
Closing Beam or Loop Input	23
Unidirectional Traffic with Free Exit Loop	24
Bi-Directional Traffic with Free Exit Loop	24
Non - Memory Input (NMI)	27
Ticket Vend Interlock (T.V.I.)	27
Commissioning	28
Diagnostic LEDs	31
Manual Release	31
Maintenance	32
Fuses	32
Boom Head Assembly	33
Enclosure Assembly	35
Wiring Diagram	36
Specifications	37
Glossary	38







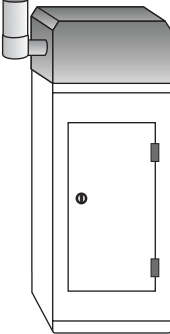

Introduction

A CENTURION ACCESS AUTOMATION system is a quality product designed to give many years of trouble free service.

PLEASE READ THE INSTRUCTIONS CAREFULLY

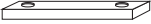
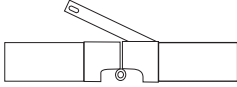
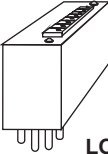
Basic Kit

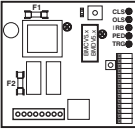
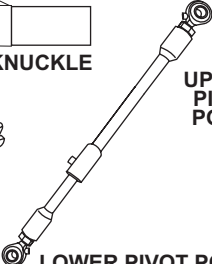
The boom kit comprises of one or more components shown in the identification list below.

ENCLOSURE & GEARBOX COMPONENTS	
	 6m BOOM ARM
	 4.5m BOOM ARM
	 3m BOOM ARM
ENCLOSURE AVAILABLE IN MILD OR STAINLESS STEEL	
Mounting Hardware (Part of Gearbox and Enclosure)	
	 HOLDING DOWN BAR
NB. Mounting rawl bolts are not included (use 4 x M16x150)	
Jack-Knife Assembly (Optional)	Electronics
 JACK-KNIFE KNUCKLE	 LOOP DETECTOR UNIT (optional)
 JACK-KNIFE SUPPORT PILLAR	 CP91 CONTROLLER
 UPPER PIVOT POINT	
 LOWER PIVOT POINT	

Recommended Tools



SPANNER
1 x 10mm/1 x 13mm
1 x 17mm/1 x 19mm

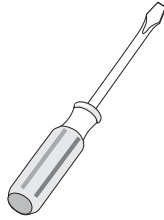

SCREW DRIVER
3,5mm FLAT
No 1. PHILLIPS

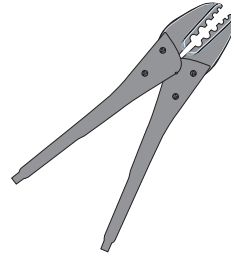

**CRIMPING TOOL
AND PIN LUGS**

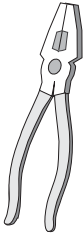

**PLIERS/SIDE
CUTTER**

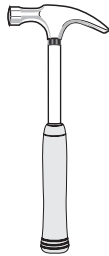

HAMMER

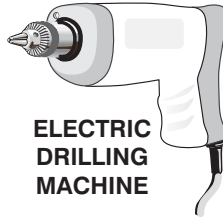

**ELECTRIC
DRILLING
MACHINE**



MASONRY BITS
16mm

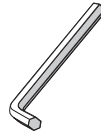

ALLEN KEYS
3mm ACROSS FLATS
8mm ACROSS FLATS
10mm ACROSS FLATS



TAPE MEASURE

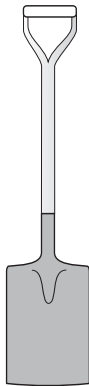

SPADE

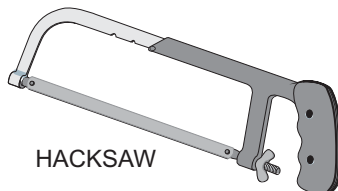

HACKSAW

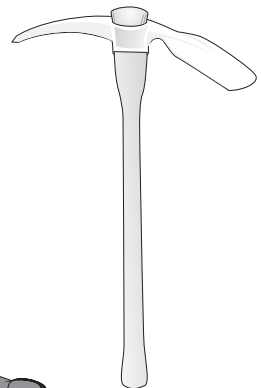

PICK

Types of Boom

ARM LENGTH

There are three standard arm lengths available:

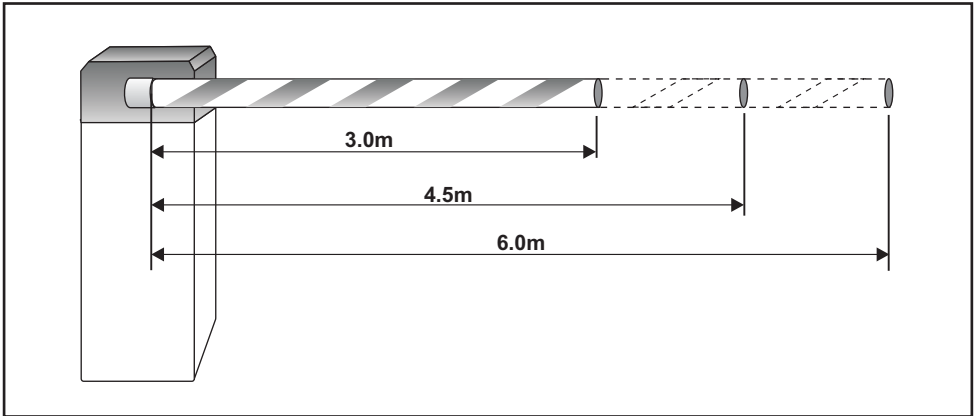

OPERATIONAL MODES

Two standard operational modes are available:

- SIMPLEX (sometimes called Domestic) - Use BMDV5.X firmware
- COMPLEX (sometimes called Commercial) - Use BMCV5.X firmware

The mode is determined by the microprocessor fitted to the CP91 control card as well as selecting which loop detectors are required, (See next section).

DETERMINATION OF OPERATIONAL MODE

The mode is determined by the microprocessor fitted. Locate the label on the microprocessor to find out what operational mode will be effective.

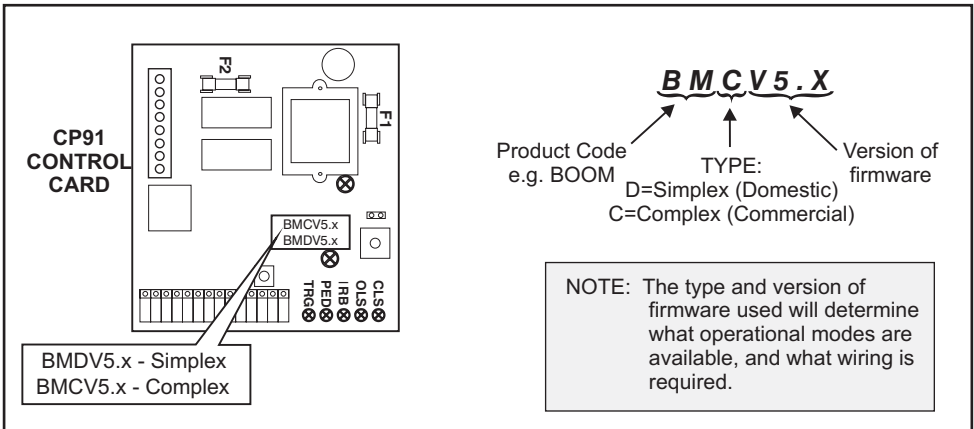

MAJOR FEATURES OF OPERATIONAL MODES

SIMPLEX MODE (B M D V 5.X)

Raising and lowering of the boom is done via a remote control or pushbutton.

Selectable, adjustable autoclose ($\pm 8 - 35$ Seconds)

There is one safety input for use with I/R beams or inductive loop sensors. This input can be used to provide vehicle presence detection and auto close inhibit.

Potential free contact for external security light etc.

COMPLEX MODE (B M C V 5.X)

Memory input (MI) for cardreader input etc.

Non-memory input (NMI) for ticket vendor or cash register input.

Ticket vend interlock (TVI) via potential free contact to inhibit ticket issue if barrier is opening or open.

Barrier close /safety input, either loop detector (recommended) or infrared beam.

See Glossary, Section 14.0 for definition of non standard terms.

Orientation

The following orientations are possible:-

The factory default is Orientation 1 for single barriers. See section 7.3 for details of converting to other orientations.

If barriers are to be paired, (e.g. in a wide entrance of say 6 metres, which requires 2 x 3 metre booms, then the pairs must be selected with one unit as orientation 1 and the other as orientation 2).

ORIENTATION 1 and 2

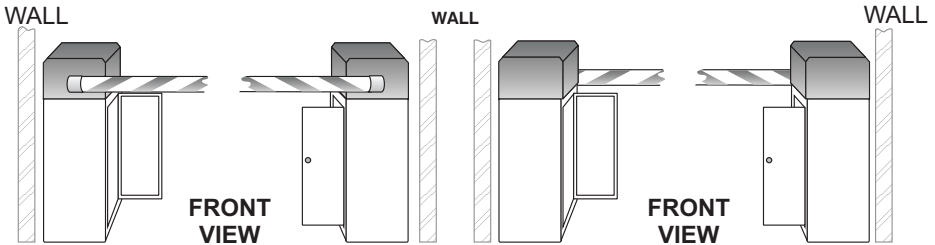

PLAN VIEW

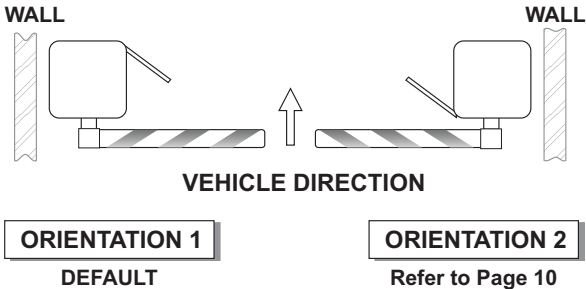

PLAN VIEW

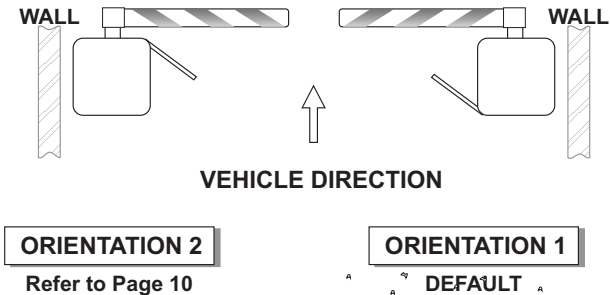

Cabling Requirements

SIMPLEX (Domestic) (Typical Application)

IMPORTANT :

Before doing any cabling, check which operational mode is required for the barrier. (See Section 4.1)

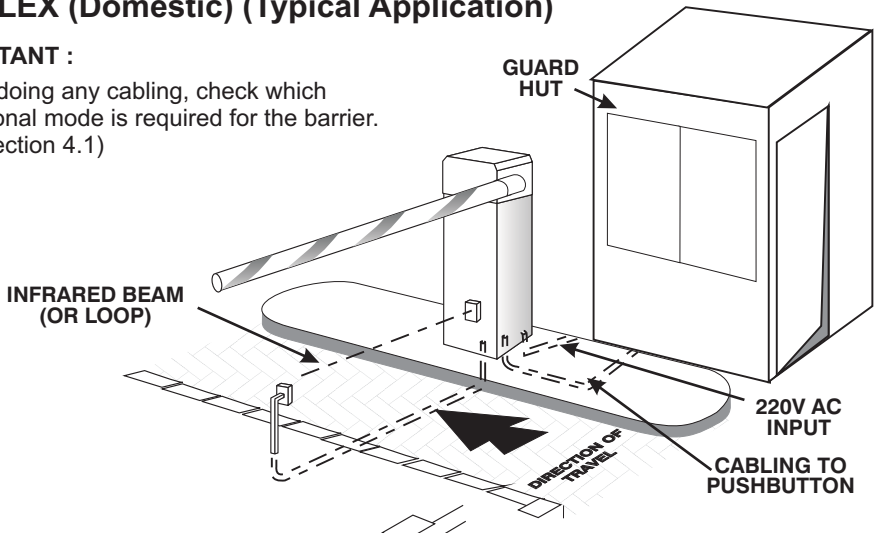

1. Guard controls operation of barrier using pushbutton inside guard hut.
2. Infra red safety beam can be replaced with inductive loop detector, fitted to the "safety loop" relay base.
3. Fit BMDV5.X microprocessor to CP91 control card.

COMPLEX (Commercial) (Basic Application)

No Ticket Spitter

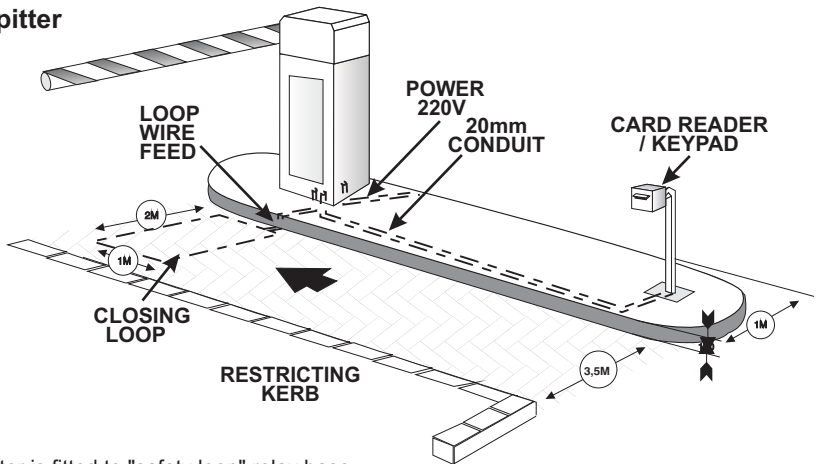

1. Loop detector is fitted to "safety loop" relay base.
2. Card reader is connected to MI input.
3. Fit BMCV5.X microprocessor to CP91 control card.

COMPLEX (Commercial) Access to parking area with ticket spitter

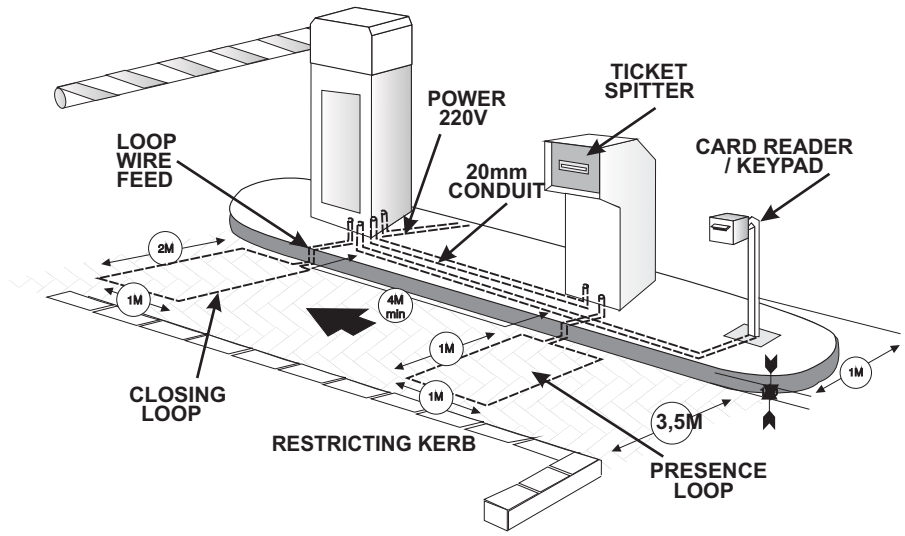

1. "CLOSING" loop detector is fitted to "Safety loop" relay base;
2. "Presence" loop is part of ticket spitter;
3. Fit BMCV5.X microprocessor to CP91 control card.

COMPLEX (Application with Free Exit Loop - Bi-Directional Traffic)

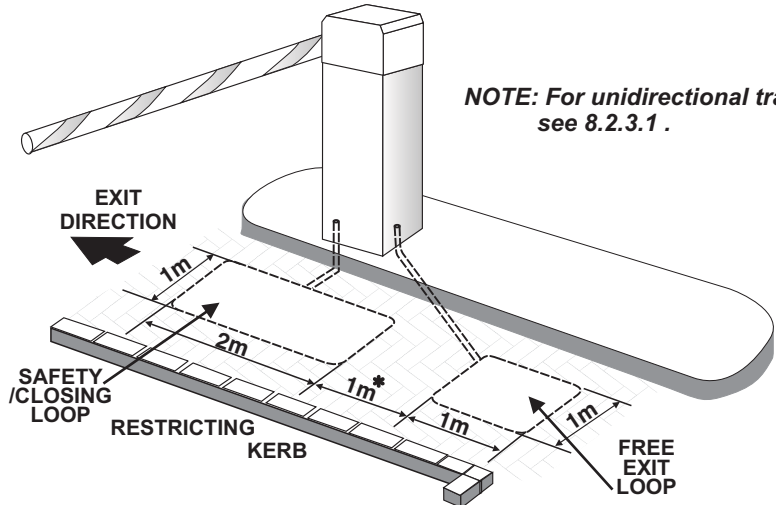

- * 1. This distance must be less than a car length, if bi-directional traffic is required.
- 2. Use BMCV5.X Microprocessor.
- 3. Fit both safety and free exit loop detectors.

Counterbalance Spring Selection

Boom Pole Profile	Pole Length	Number of Springs Required	Spring Part Number
76.2 x 1.27 Aluminium Tube = 0.81kg/m	3m	1	SPRINGTM90
76.2 x 1.27 Aluminium Tube = 0.81kg/m	4.5m	2	SPRINGTM90
76.2 x 1.27 Aluminium Tube = 0.81kg/m	6m	3	SPRINGTM90
76.2 x 1.8 Aluminium Tube = 1kg/m	3m	1	SPRINGTM90
76.2 x 1.8 Aluminium Tube = 1kg/m	4.5m	2	SPRINGTM90
76.2 x 1.8 Aluminium Tube = 1kg/m	6m	4	SPRINGTM90
80 x 1.5 Aluminium Tube = 1kg/m	3m	1	SPRINGTM90
80 x 1.5 Aluminium Tube = 1kg/m	4.5m	2	SPRINGTM90
80 x 1.5 Aluminium Tube = 1kg/m	6m	4	SPRINGTM90

NB: For counterbalance spring installation see page 18.

Installation

POSITIONING

- ▶ Determine correct position for barrier
- ▶ Check orientation of door - see Section 5.0
- ▶ Prepare hole for concrete foundation 500 x 500 x 300mm.

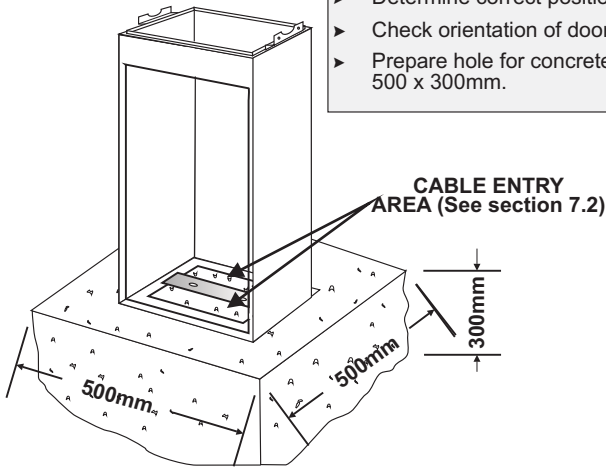

BOLTING DOWN ARRANGEMENT

Alternative 1

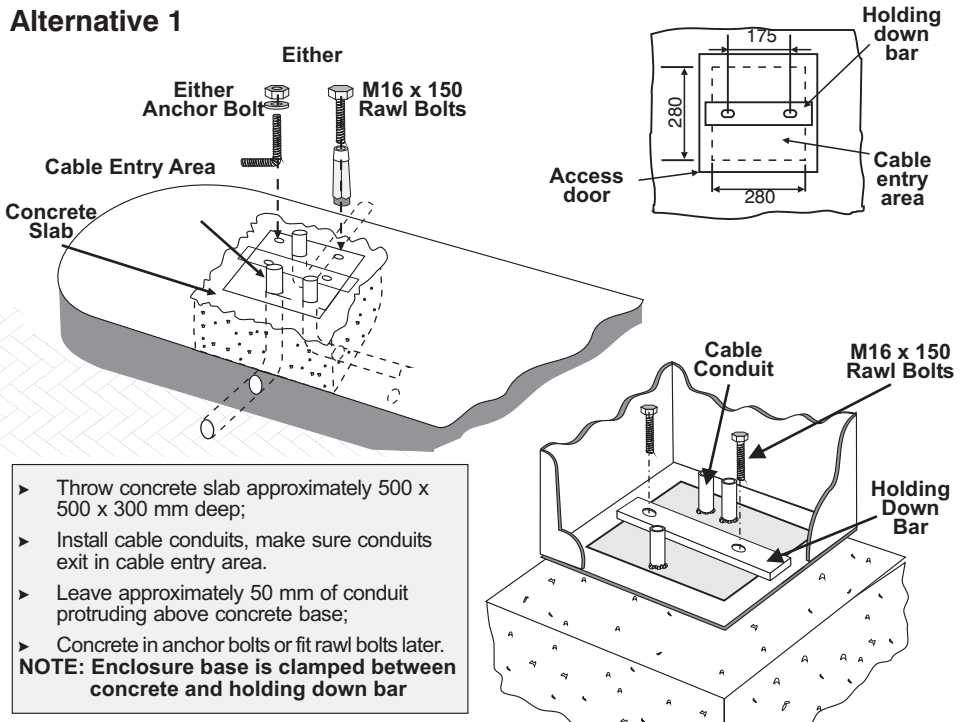

- ▶ Throw concrete slab approximately 500 x 500 x 300 mm deep;
- ▶ Install cable conduits, make sure conduits exit in cable entry area.
- ▶ Leave approximately 50 mm of conduit protruding above concrete base;
- ▶ Concrete in anchor bolts or fit rawl bolts later.

NOTE: Enclosure base is clamped between concrete and holding down bar

Alternative 2

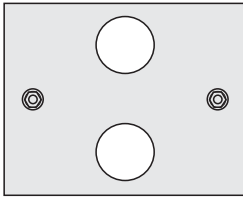

LEAVE AT LEAST 70mm

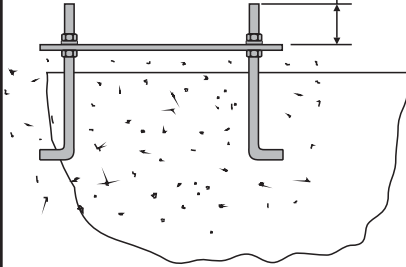

- ▶ Before pouring the concrete ensure that the mounting plate is positioned correctly.

- ▶ Tighten top and bottom nut to aid in positioning the plate when the concrete is poured.
- ▶ Place the plate above surface of concrete.
- ▶ Leave the concrete to dry.

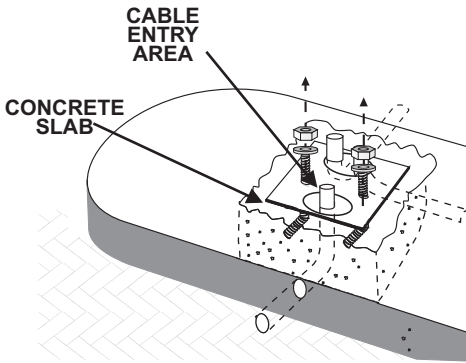

- ▶ Unscrew the nuts and washers, and remove them.
- ▶ Arrange enclosure in position and clamp it between the mounting plate and the holding down bar supplied using the nuts and washers that were removed.

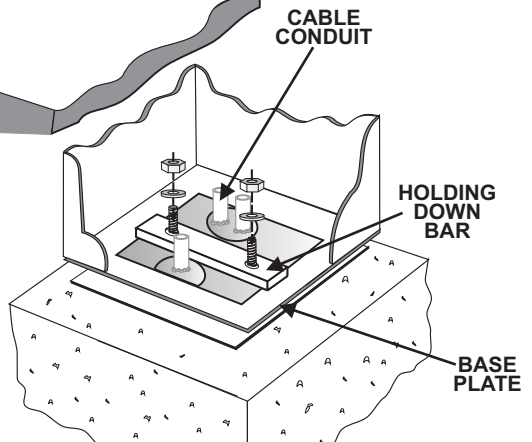

CONVERTING ORIENTATIONS

(To convert a factory default orientation 1 to orientation 2)

The following modifications are done only if it is necessary to change the orientation of the arm e.g. the unit has been incorrectly ordered, or site conditions have changed.

- NB. 1. Make sure that all power to the unit is switched off.**
- 2. Make sure that the counterbalance springs are retracted.**

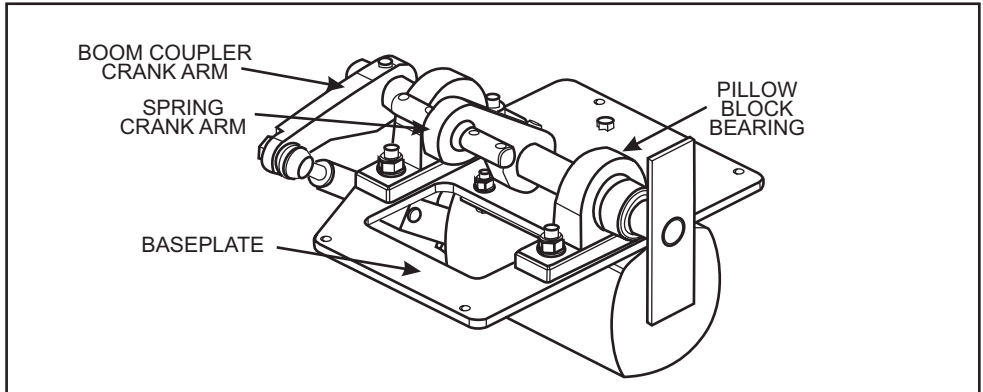

Step 1: Remove M12 Cap Screw

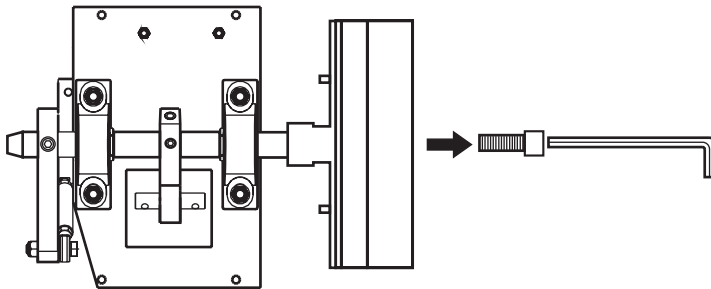

Step 2: Loosen the boom coupler from the shaft by inserting and tightening the M16 Bolt

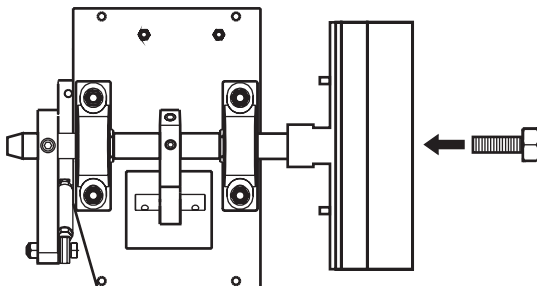

Step 3: Remove the boom coupler

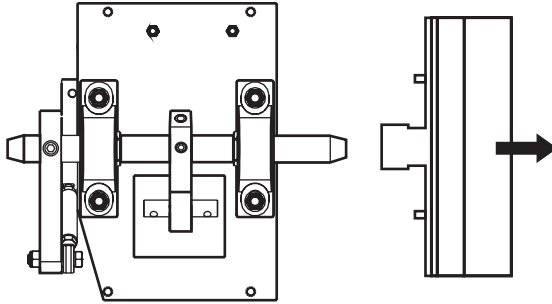

Step 4: Push the boom coupler onto end of shaft

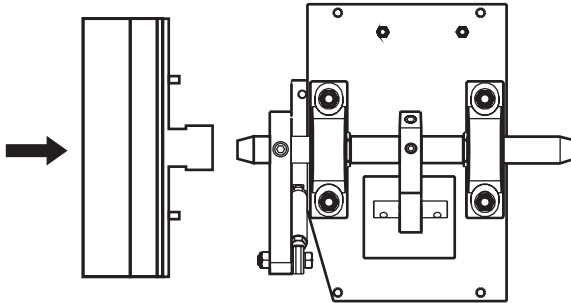

Step 5: Fasten with M12 cap screw.
NB. Torque cap screw to $\pm 180\text{Nm}$

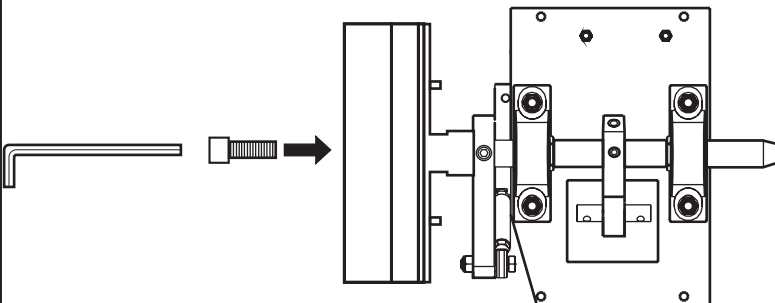

CORRECT BOOM COUPLER CRANK ARM ALIGNMENT IN "BOOM LOWERED" POSITION

NB. The alignment of the boom coupler crank arm is a factory setting but may need adjustment over time to ensure that:

1. The boom arm is horizontal.
2. In a power failure situation the arm will raise automatically, or the boom is self-lock.

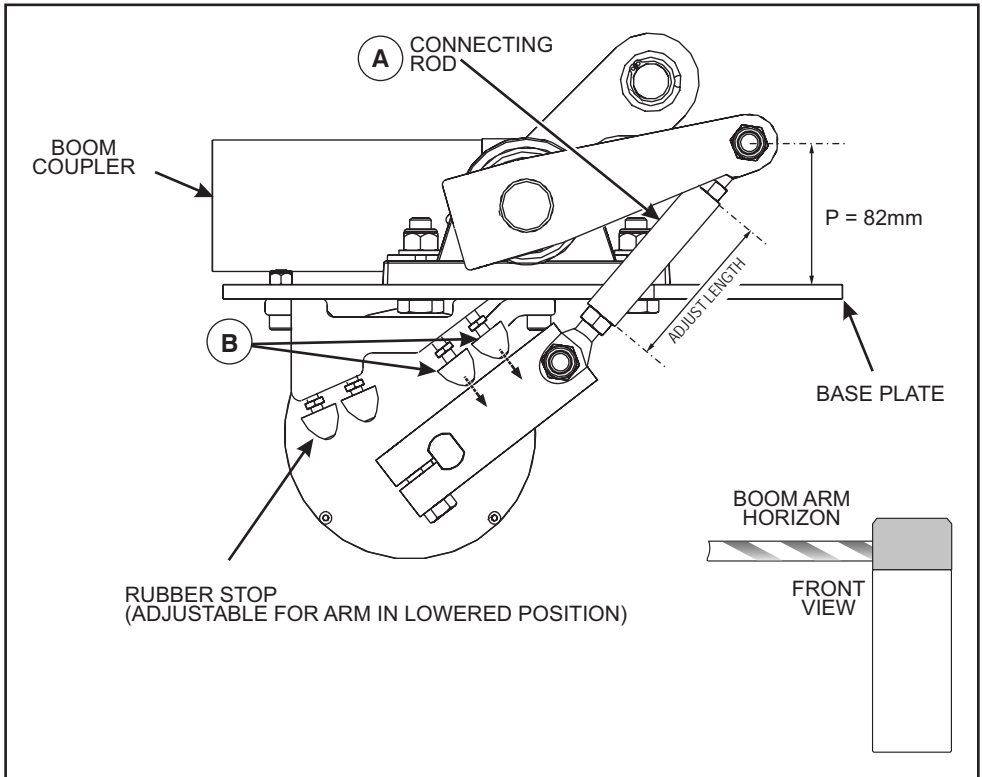

- adjust the length of the connecting rod (A) to ensure that the boom Arm is horizontal.
- adjust the height of the rubber stoppers (B) to ensure that the boom Arm will raise in the event of a power failure and be self locking.
- with power on the motor and the stoppers slightly compressed the Drive arm and connecting arm must be in a straight line.

BOOM POLE ASSEMBLY

Fitting the Boom Pole

1

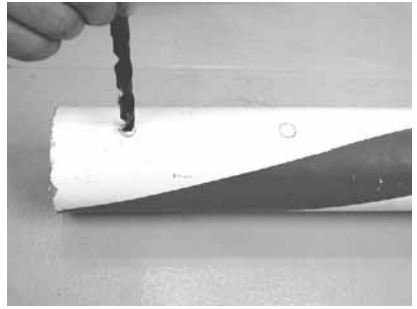
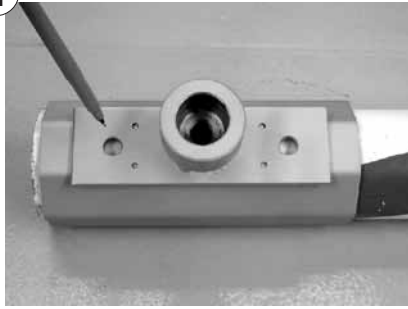

Using the external clamping piece as a template, mark and drill the 10.5mm holes in the boom pole.

2

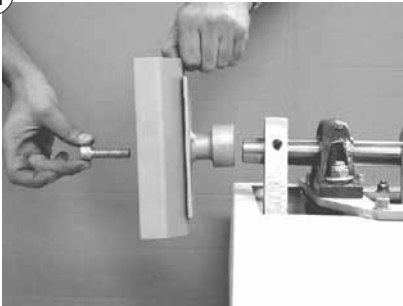

Fasten the external clamping piece onto the end of the shaft using the M12 x 55 cap screw

3



Tighten the cap screw using a 12mm allen key. To prevent the boom and clamping piece from slipping on the shaft, ensure that the cap screw is fastened very tightly (approx. 180Nm)



4

Fit the boom pole into the external clamping piece. Fit the M10 bolts through the internal clamping piece and slide the assembly through the end of the boom pole. Locate the bolts in the holes in the boom pole.

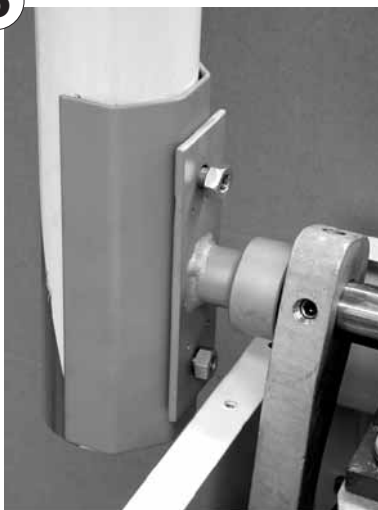
5

Fasten the M10 nuts onto the bolts and tighten.

Removing the Boom Pole

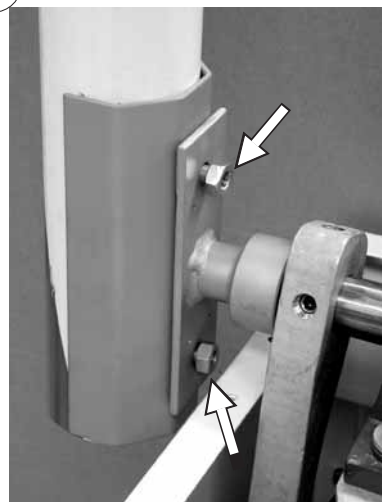
1

Remove the M10 nuts.

2

Remove the M12 cap screw.

3

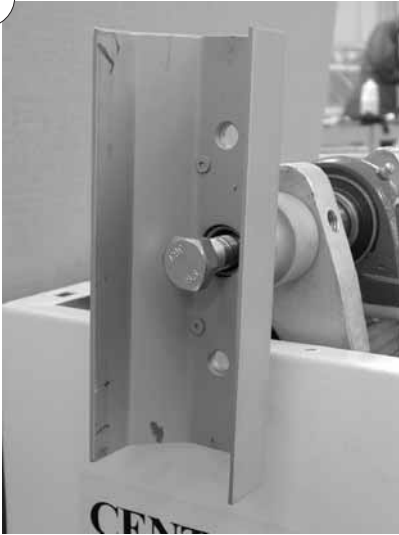

Insert and tighten the M16 bolt.

4

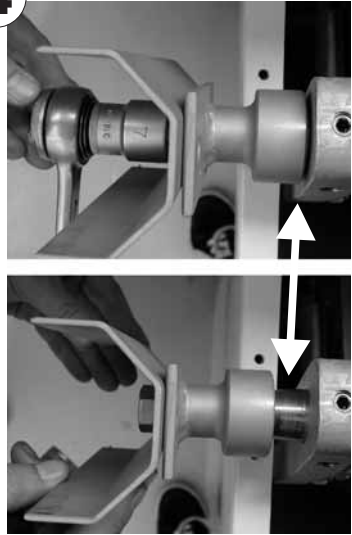

As the bolt is tightened against the end of the shaft, this action will pull the external clamping piece away from the shaft.

COUNTERBALANCE SPRING INSTALLATION

(See Table on page 9)

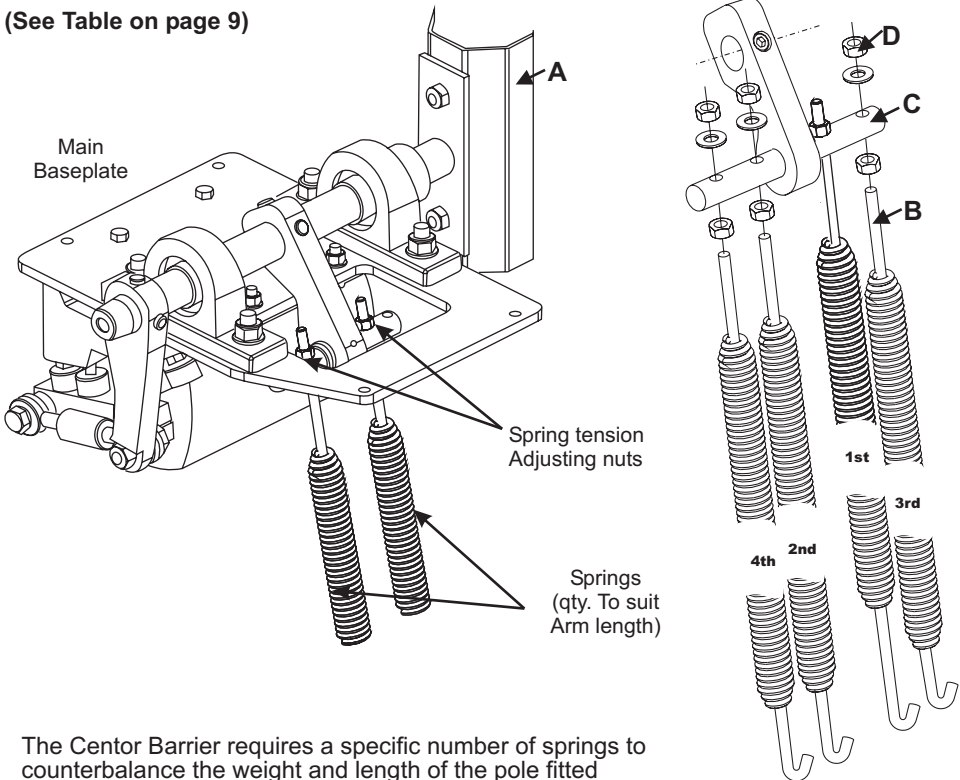

The Centor Barrier requires a specific number of springs to counterbalance the weight and length of the pole fitted (See Table on page 9.)

1. Determine the number of springs required (See Table on page 9.)
2. Ensure the pole adaptor (A) is in the vertical position.
3. Slip the threaded rod end of the spring (B) into the spring arm shaft (C) through the holes provided. Observe the order shown in the diagram.
4. Hook the bent tail of the spring into the hole provided in the base of the cabinet. See inset on the right hand side.
5. Wind the lock nut & washer provided (D) onto the threaded rod (B)
6. Carefully tension the springs by winding the nut down the threaded portion until they come into contact with the spring arm shaft. Take care to wind the nut down equally for all the springs present.
7. The spring tension should be set to balance the pole at 45° to the ground with no power present.
8. When satisfied that the barrier is balanced, put on power & cycle it. Watch for springs unhooking or the motor straining against the spring tension.

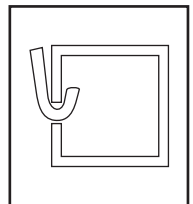

NB: When installing the springs the boom pole must be in the vertical position. ANY work on the springs must be done in this state. Should there be a need to cycle the operator KEEP YOUR HANDS CLEAR of the barrier entirely.

Electrical Connections

(See Section 13 for wiring diagram)

The instructions are broken down into two sections:

SIMPLEX type boom logic (Section 9.1)

COMPLEX type boom logic (Section 9.2)

Connections are made to the 19 way terminal strip mounted on the chassis plate fitted inside the base.

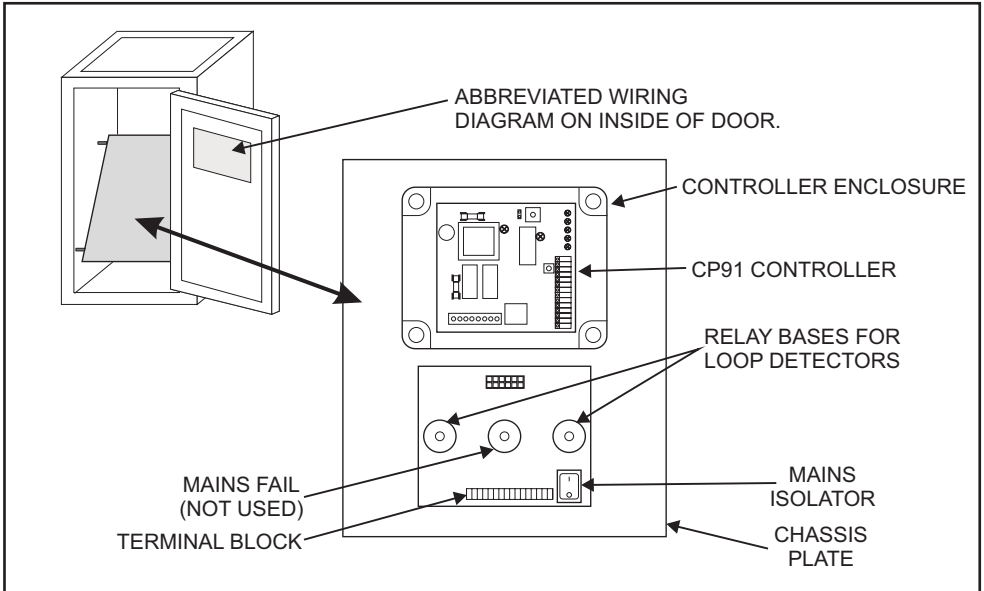

N.B. Before doing any connections check which microprocessor is fitted to the CP91 control card (see Section 4.1).

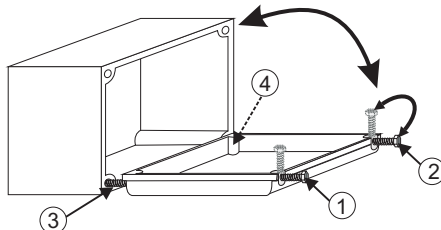

- To work on controller loosen studs marked ① and ② fully.
- Loosen studs marked ③ and ④ but do not remove.
- Rotate cover down on studs ③ and ④ as shown above.
- Rotate studs ① and ② as shown above so that they are not lost.

SIMPLEX TYPE BARRIER LOGIC

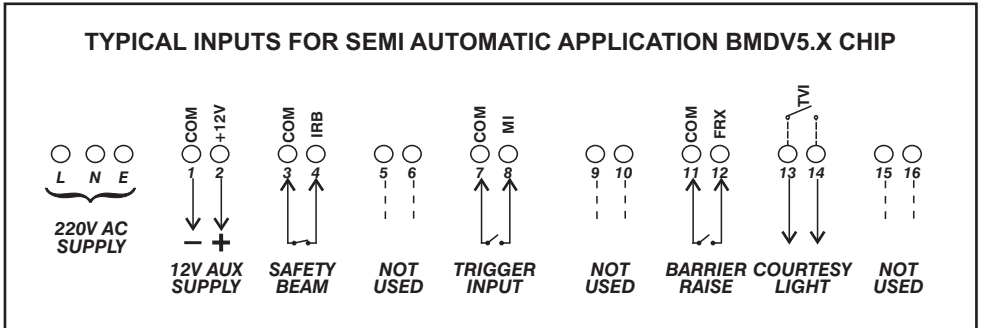

Notes:

- 1) trigger input functions as " start - stop - reverse"
- 2) safety beam prevents barrier from closing onto a vehicle
- 3) 12v aux supply can be used to power safety beams and radio receiver.

AC MAINS SUPPLY

Connect 220V AC, 50 HZ supply to terminals L, N, E

Only Switch "ON" isolator after all connections have been made

TRIGGER INPUT

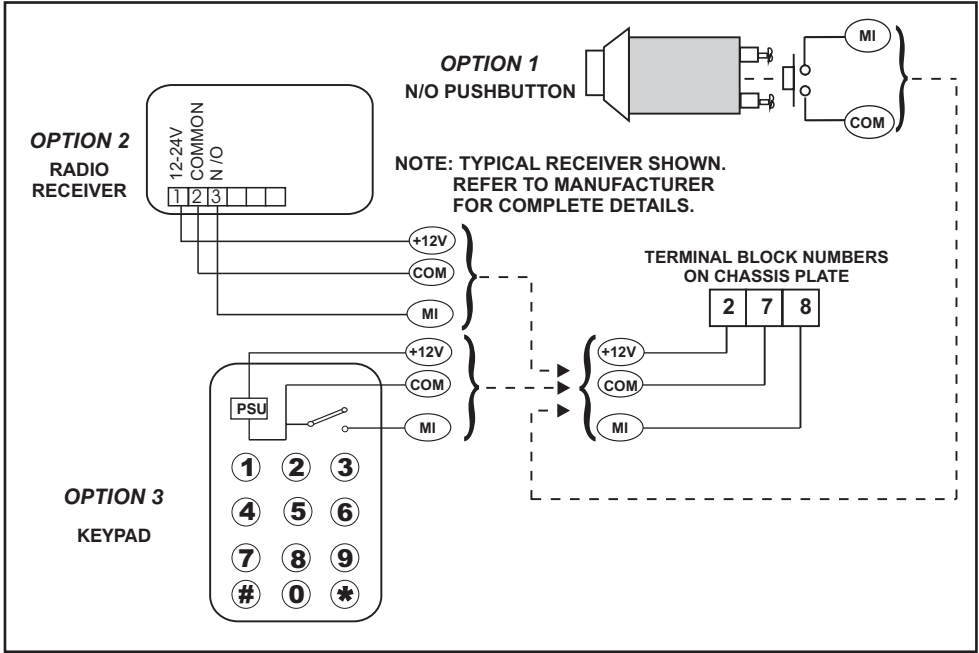

SAFETY BEAM

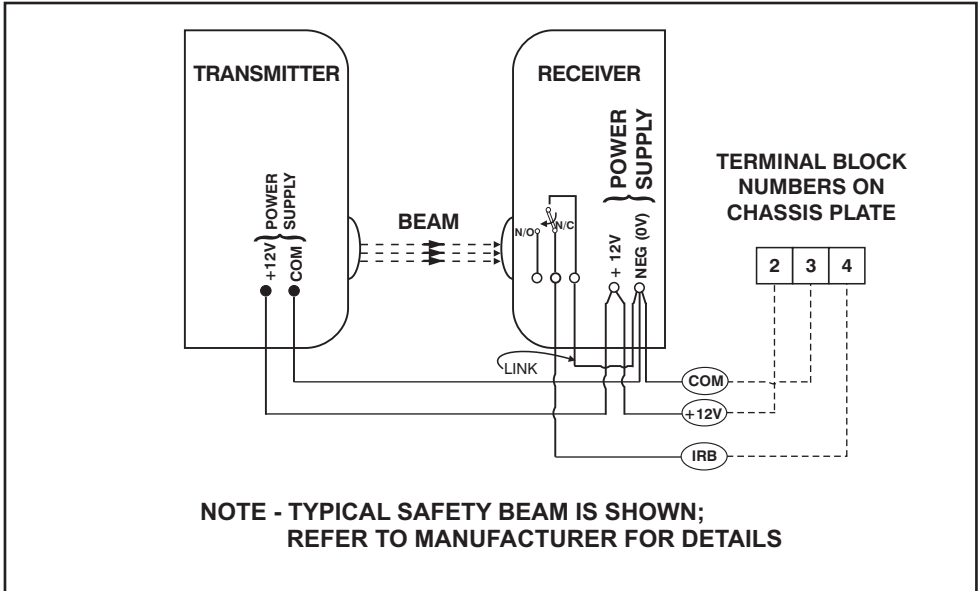

COURTESY LIGHT

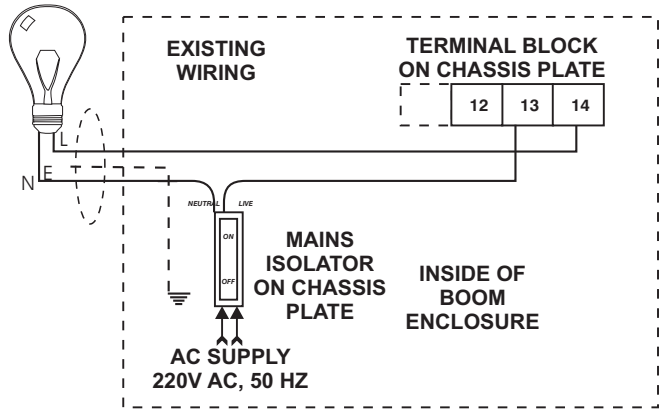

COMPLEX TYPE BARRIER LOGIC

TYPICAL INPUTS FOR COMMERCIAL APPLICATION BMCV5.X CHIP

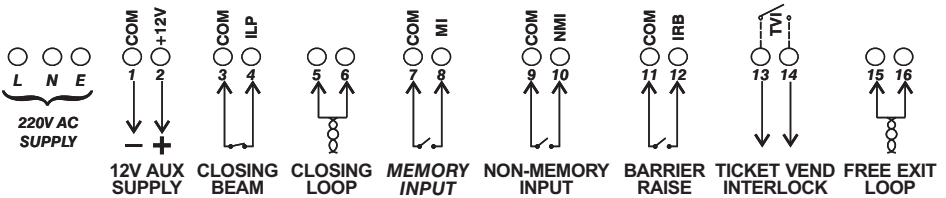

Notes:

- 1) Closing beam can be used if loop detector is not fitted
- 2) Memory input "counts" triggers
- 3) Non memory input activates when contact is closed and then released.
- 4) Barrier raise will keep the barrier raised while the contact is closed.
- 5) Ticket vend interlock is "closed" when the barrier is closing or closed.

AC MAINS SUPPLY

See Section 8.1.1

MEMORY INPUT

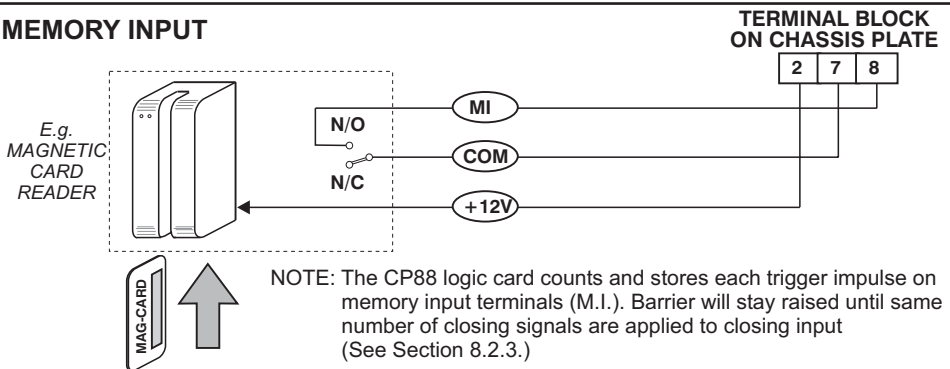

CLOSING BEAM OR LOOP INPUT

To lower the arm requires a closing signal. This is supplied by either a closing beam or Inductive loop detector.

It is recommended that 2 sets of ir beams are installed, spaced as shown, wired in series. This prevents a person walking through the entrance, while the Barrier is raised, to inadvertently cause the barrier to lower.

IR BEAM

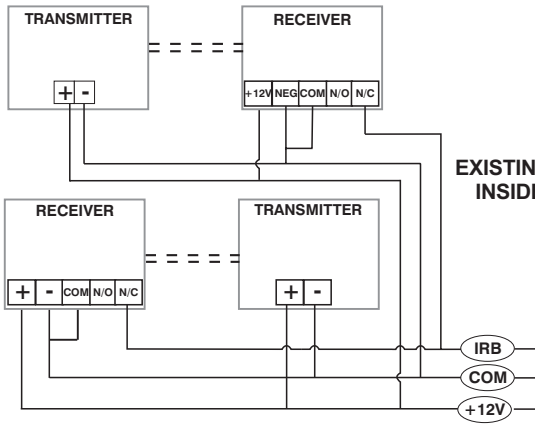
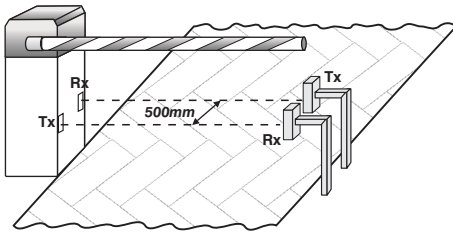

Inductive loop detector fitted To chassis plate inside boom Enclosure plugged into "safety Loop" relay base.

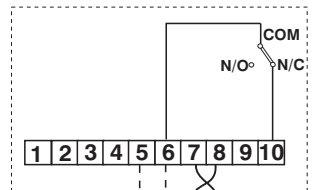
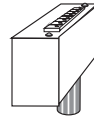

EXISTING WIRING INSIDE BOOM

TERMINAL BLOCK ON CHASSIS PLATE

INDUCTIVE LOOP

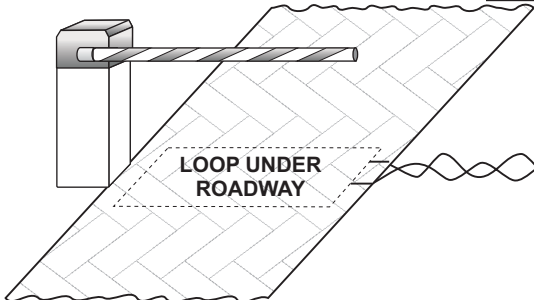

TWISTED WIRE

N.B. THE CLOSING BEAM, OR LOOP, ALSO ACTS AS A SAFETY. THEREFORE MOUNT BEAM OR LOOP DIRECTLY UNDER BARRIER ARM.

UNIDIRECTIONAL TRAFFIC WITH FREE EXIT LOOP

Note: 220V loop detectors are normally used
In centor barriers, 220V AC type LD100

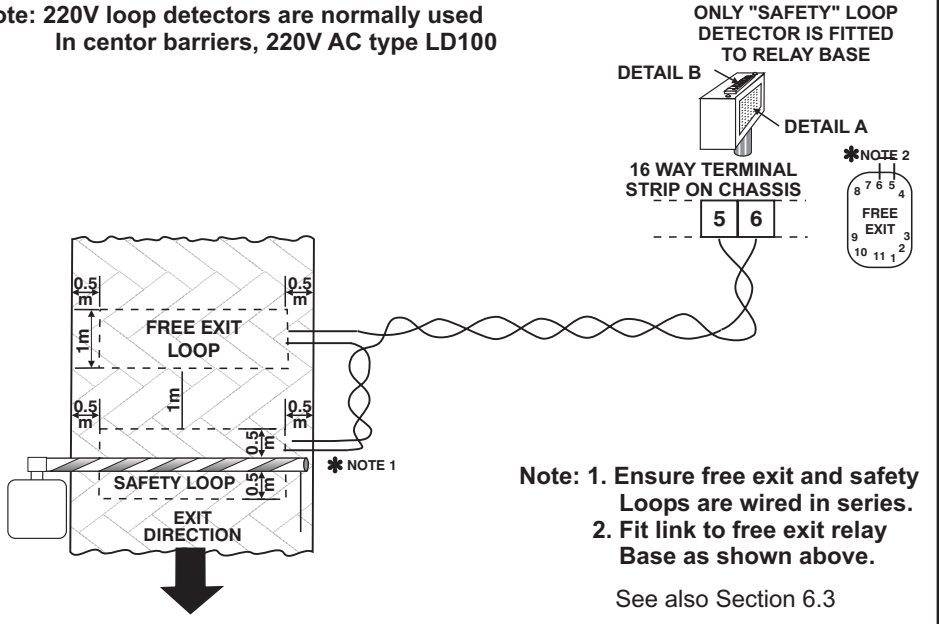

BI-DIRECTIONAL TRAFFIC WITH FREE EXIT LOOP

Note: 220V loop detectors are normally used
In centor barriers, type LD100.

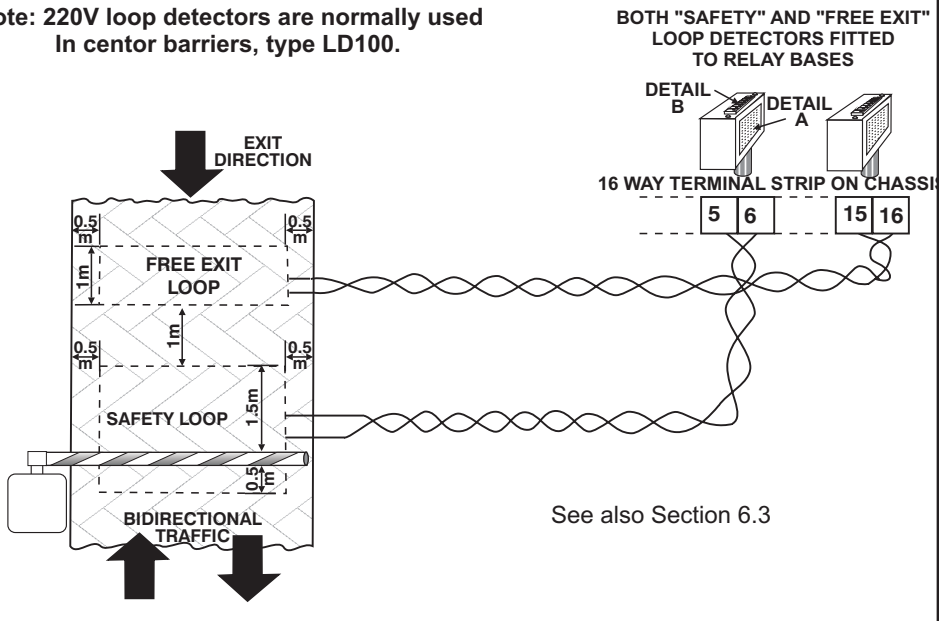

LOOP DETAILS

STANDARD FEATURES OF THE DETECTOR ARE:

- **Reset Switch**

The reset switch enables the detector to be manually reset during commissioning and testing.

This results in the detector re-tuning the sensing loop and becoming ready for vehicle detection.

- **Selectable Pulse Time**

This feature sets the length of time that the pulse relay will be energised for. 1 Second or 0.2 Second.

- **Pulse Relay Selection**

The Pulse relay may be configured to energise on detection of vehicle leaves the loop or when the vehicle leaves the loop.

- **Switch selectable Sensitivity**

Four sensitivity settings are available on the switches to allow flexibility in configuration.

1	High	0.01%	5	0.2%	
2		0.02%	6	0.5%	
3		0.05%	7	1%	
4		0.1%	8	Low	2%

- **Switch selectable Frequency**

Two frequency settings are available to prevent cross-talk between adjacent loops.

- **Permanent Presence Option**

This feature ensures detection of the vehicle will be maintained when the vehicle is parked over the loop for extended periods.

- **Sensitivity Boost**

This feature sets the undetect level to maximum sensitivity and is used to prevent loss of detection of high-bed vehicles.

- **Filter Option**

This option is used to provide a delay between detection of the vehicle and switching of the output relay. This delay is normally used to prevent false detection of small or fast moving objects.

- **Loop Fault Indicator**

This LED Indicator is illuminated when the loop is either open circuit or short circuit and is used to give a visual indication of a faulty loop.

**VEHICLE LOOP DETECTOR
LD 100**

	ON	OFF	WIRING CONNECTIONS	
RESET	ON	OFF	CONNECTION	PIN
SENS 0.02%	-	S7/S8/S9	220V AC	1
SENS 0.01%	S9	S7/S8	220V AC	2
SENS 0.05%	S8	S7/S8	PULSE RLY N/O	3
SENS 0.1%	S8/S9	S7	PULSE RLY COM	4
SENS 0.2%	S7	S8/S9	PRESENCE RLY N/O	5
SENS 0.5%	S7/S9	S8	PRESENCE RLY COM	6
SENS 1%	S7/S8	S9	LOOP	7
SENS 2%	S7/S8/S9	-	LOOP	8
FREQ.	LOW	HI	EARTH	9
ASB	ON	OFF	PRES. RLY N/C	10
FILTER	2SEC	OFF	PRES. RLY N/C	11
PERM.PRES	ON	OFF		
PULSE MODE	UNDET	DET		
PULSE TIME	1SEC	0.2SEC		

WARNING: DO NOT OPEN HOUSING WITH POWER ON.

DETAIL A

POWER

DETECT

LOOP FAULT

RESET

SENS

SENS

SENS

FREQ

ASB

FILTER

PERM PRES

PULSE MODE

PULSE TIME

**PROCON
ELECTRONICS**

DETAIL B

(Recommended settings)

Note: If two detectors are used,
set different frequencies (S6)

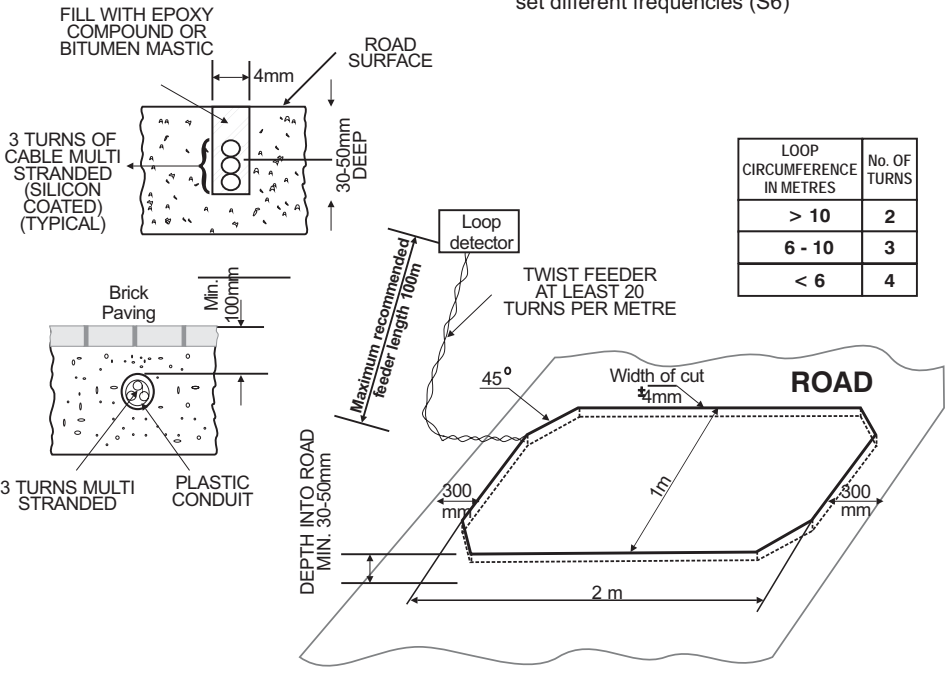

- Wire: 1.5mm squared multi stranded cable (use silicon coated if placed directly into the ground)
- Spacing between two adjacent loops > 2 metres. Alternate adjacent loops using different numbers of turns.
- Loop and feeder should comprise one length of unjoined wire. If joints are made, then solder joint.

'Use screened feeder cable in electrically noisy environments or where feeder runs parallel to Power cables.

NON MEMORY INPUT (NMI)

An example of "NMI" is the signal given by a ticket vending machine.

NOTE: NMI responds only when contact goes from CLOSED to OPEN.

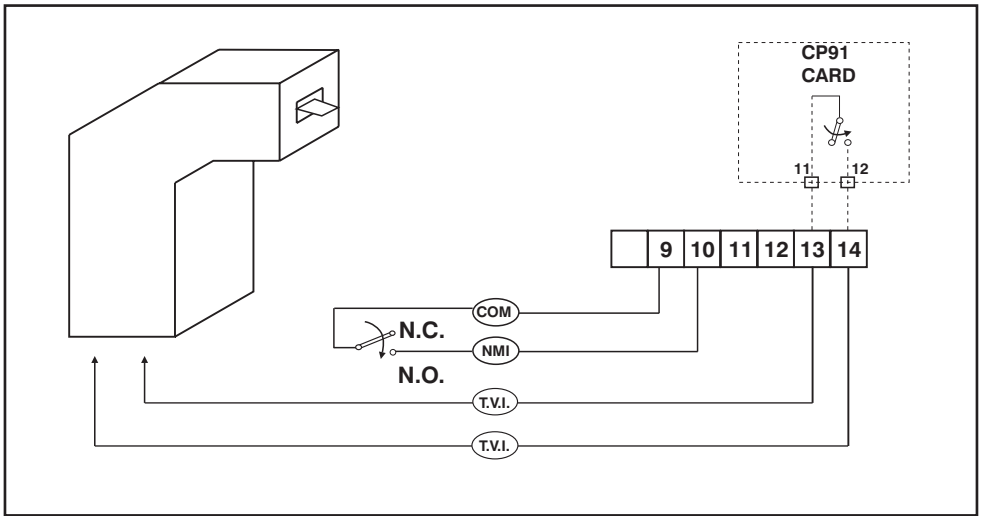

TICKET VEND INTERLOCK (TVI)

The " T.V.I. " Signal from the CP91 CARD will prevent the ticket splitter from issuing another ticket until the arm is closing or closed.

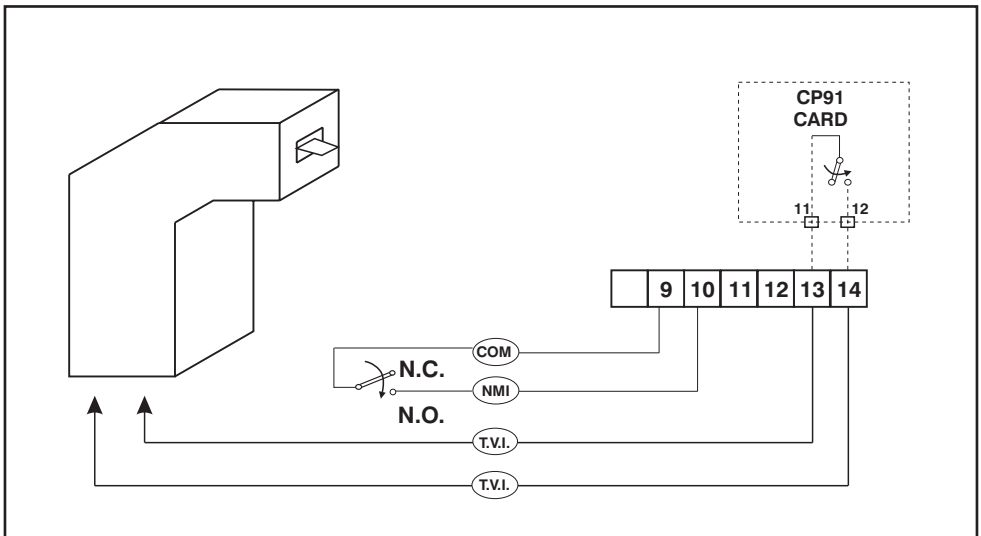

Commissioning

Before any commissioning is done it is important to make sure that the counterbalance springs are providing sufficient force to balance the weight of the arm.

ADJUSTING SPRING TENSION

Depending on the length of the boom pole used different numbers of counterbalance springs are used. See Table on page 9.

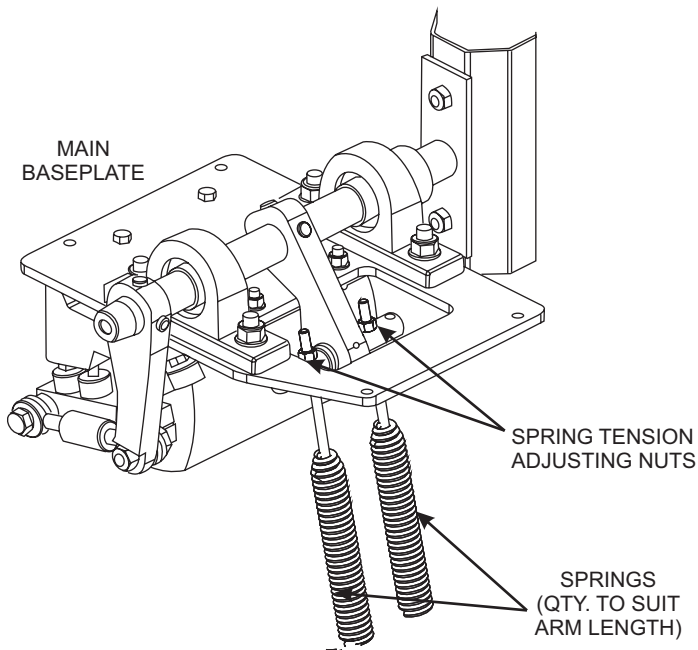

- Step 1** : Make sure the Boom pole is lowered
- Step 2** : Switch off power to the system (isolator)
- Step 3** : Check that the boom pole rises slowly
- Step 4 a**: Increase tension if boom pole does not rise or
- b**: Release tension if boom pole rises too quickly

NB. Spring tension is correct when the arm rises slowly when power is removed from the motor.

N.B. See Section 10 for a summary of the Diagnostic LEDs available on the controller.

Switch on AC power and ensure the green “MAINS” on LED on the CP91 control card illuminates:

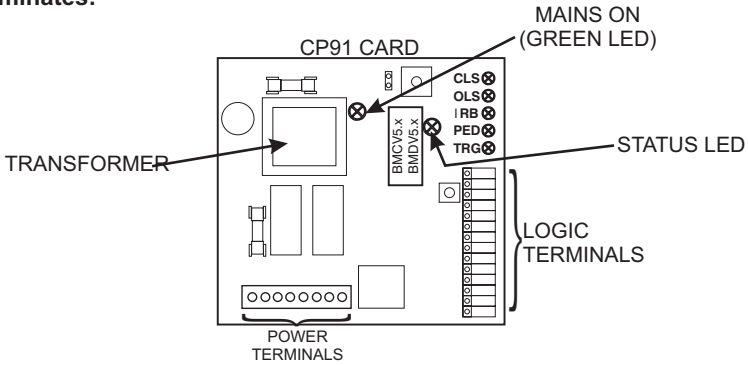

Trigger boom and check that TRG (i.e. MI signal) or PED (i.e. NMI signal) LED illuminates with trigger input.

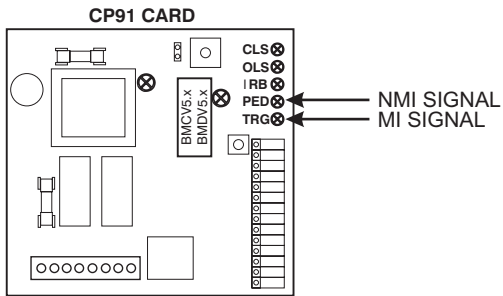

AUTO-CLOSE (SIMPLEX MODE ONLY)

Ensure that the auto-close link is fitted onto the pins provided.

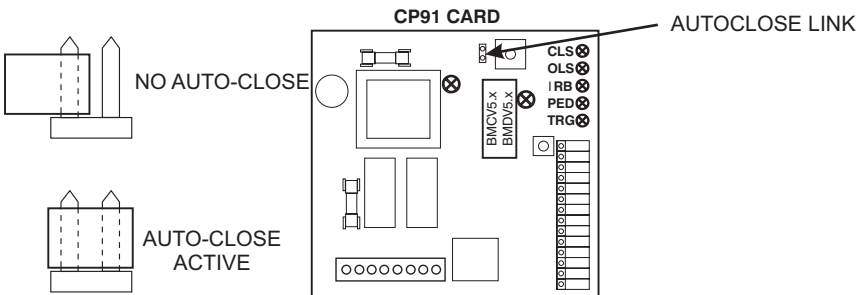

NOTE: In the COMPLEX Mode the auto-close link has no effect on the operation of the unit.

JACK-KNIFE ASSEMBLY (if fitted)

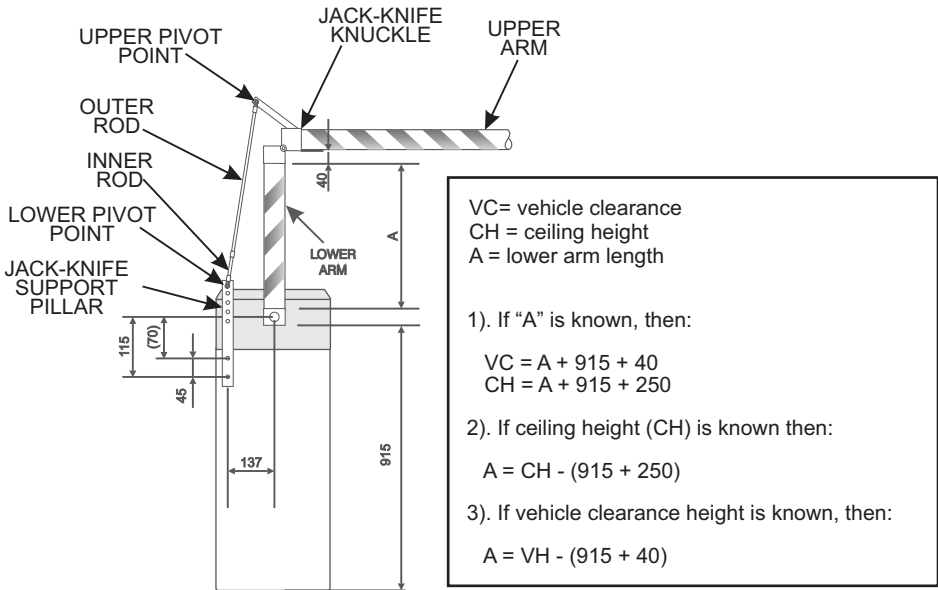

- Fit jack-knife support pillar to enclosure using pilot holes in enclosure as a template (drill size - 6.5mm).
- Cut arm such that upper & lower arm lengths are correct (see calculations above).
- Fit jack-knife knuckle to arms as shown.
- Attach outer rod to jack-knife knuckle extension arm as shown using bolt and nuts provided. Ensure rod is free to rotate.
- Connect inner rod to jack-knife support pillar using the middle hole. Make sure that rod can pivot smoothly.
- With arm in lowered position and perfectly horizontal, adjust the length of the rod assembly by sliding the inner rod in or out of the outer rod. Once the rod assembly has been correctly adjusted, tighten the outer rod grub screw.

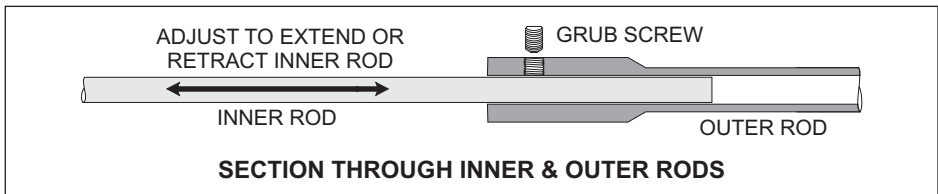

- Move arm to fully raised position and if necessary move the lower pivot point on the jack-knife support pillar either up or down (using one of the 5 holes provided) to ensure that the upper arm is horizontal.
- Check & repeat adjustments to get upper arm horizontal in both raised and lowered positions.

Diagnostic LED's

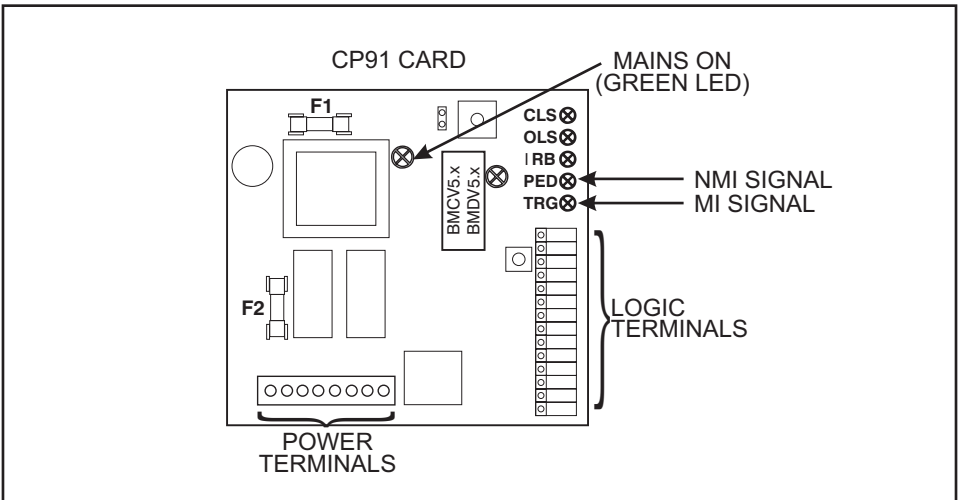

TRG - ON when MI input is present.

PED - ON when NMI input is present.

IRB - ON when safety beam/loop broken.

MAINS ON - ON when mains power present.

OLS - not used.

CLS - not used.

MANUAL RELEASE

In the event of a total malfunction of the boom SWITCH OFF MAINS POWER and arm will raise.

Maintenance

The Centurion boom requires a minimum amount of maintenance.
The following checks should be done periodically:

- Ensure all terminals are tight and that no nuts or bolts are loose.
- Check the rubber end stops, and adjust if necessary. (See section 7.4 or 7.5)

The exploded view of the boom assembly lists all item codes if spares are required.
(See 12.2 & 12.3)

FUSES

CP91 CARD

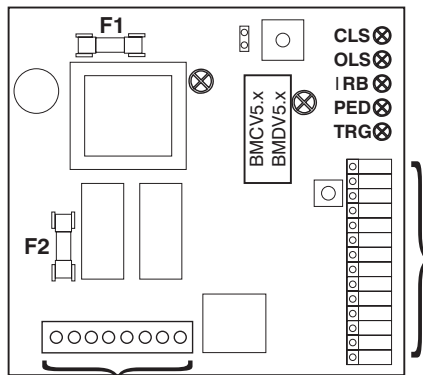

F1 - AUXILIARY, 1A Fast Blow, 5 x 20.

F2 - MOTOR, 5A Fast Blow 5 x 20.

Boom Head Assembly

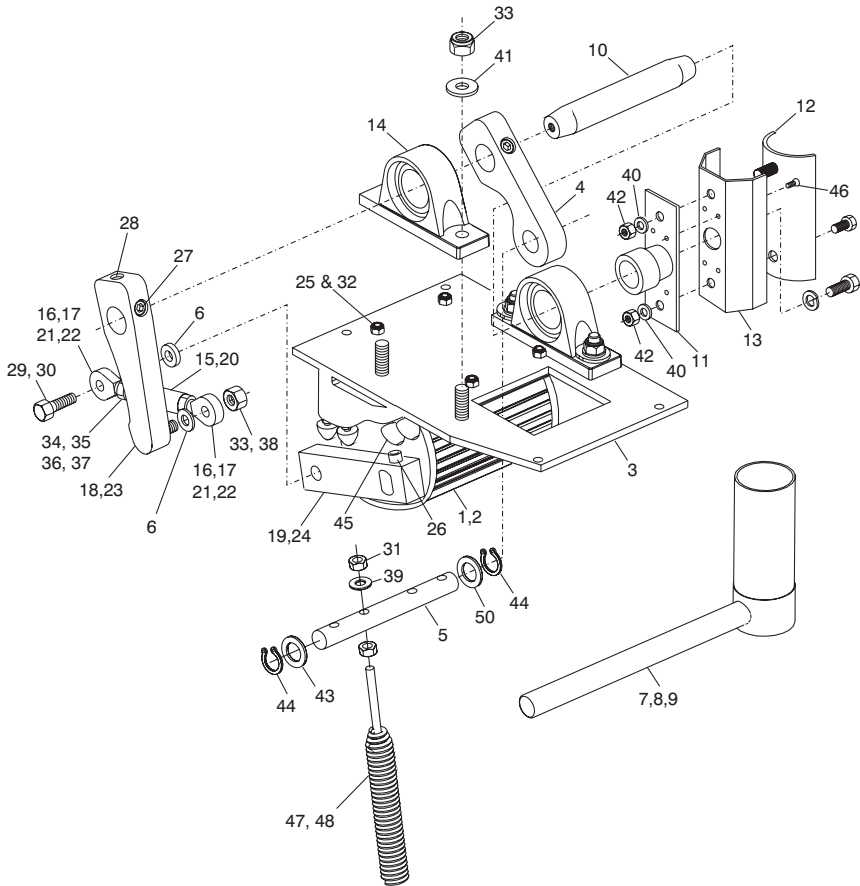

	DESCRIPTION	STOCK CODE
GEARBOX ASSEMBLY		
MAIN COMPONENTS		
1	MOTOR, Torque, 10-rpm - 3/4m Units	MTROM01000
2	MOTOR, Torque, 7.5-rpm - 6m Units	MTROB00750
3	BASEPLATE, Centor Motor	1123009000
4	CRANK ARM, Spring (including PB Bush)	1123009008
5	CROSS SHAFT, 4 Spring Connector, Centor	1123009005
6	SPACER, Connecting Arm, Centor	1123009007
BOOM COUPLER - Version 1		
7	BOOM COUPLER, Dia 71.5mm c/w Shaft (UK)	112300903E
8	BOOM COUPLER, Dia 73mm c/w Shaft	1123009003

	DESCRIPTION	STOCK CODE
9	BOOM COUPLER, Dia 75.5mm c/w Shaft (France)	112300903F
	BOOM COUPLER - Version 2 (After 2/4/2001)	
10	SHAFT, Output, Centor, Version 2	1123009010
11	CONNECTOR, Output Shaft, Version 2	1123020200
12	CLAMPING PLATE, Inside, BC, Version 2	1148010000
13	CLAMPING PLATE, Outside	1148020000
	BEARINGS	
14	BEARING, Pillow Block	BBUCP20600
	CONNECTING ROD - Version 1 (Pre March 2001, all 6m units remain as per Version 1)	
15	CONNECTING ROD, (M16LH/RH)	1123009004
16	ROD END, LH Thread, 16mm	BBPOS16LH0
17	ROD END, RH Thread, 16mm	BBPOS16LH1
18	CRANK ARM, Boom Coupler, 16mm	112300902B
19	CRANK ARM, Motor, 16mm	1123009006
	CONNECTING ROD - Version 2 (3/4.5m units only, 6m units as per Version 1)(After March 2001)	
20	CONNECTING ROD, (M12LH/RH)	112300904B
21	ROD END, LH Thread, 12mm	BBPOS12LH0
22	ROD END, RH Thread, 12mm	BBPOS12LH1
23	CRANK ARM, Boom Coupler, 12mm	112300902B
24	CRANK ARM, Motor, 12mm	112300906B
	MISCELLANEOUS FASTENERS	
25	SCREW, Cap, Galv, M8x35mm	B184108035
26	SCREW, Cap, Galv, M10x35mm	B124110035
27	SCREW, Grub, Galv, Dog Point, M12x12mm	B126112d12
28	SCREW, Grub, Galv, M12x25mm	B126112025
29	SCREW, Set, HT, Galv, M12x50mm (3/4.5m Units)	B121312050
30	SCREW, Set, HT, Galv, M16x50mm (6m Units)	B121316050
31	NUT, Full, Galv, M8	N120108000
32	NUT, Nylok, Galv, M8	N320208000
33	NUT, Nylok, Galv, M12	N320112000
34	NUT, Full, Galv, M12	N120112000
35	NUT, Full, Galv, M12, LH Thread	N1201120LH
36	NUT, Full, Galv, M16	N120116000
37	NUT, Full, Galv, M16, LH Thread	N1201160LH
38	NUT, Nylok, Galv. M16	N320116000
39	WASHER, Flat, LD, Galv, M8	W120208000
40	WASHER, Flat, LD, Galv, M10	W120101000
41	WASHER, Flat, HD, Galv, M12x30x3	W220112004
42	NUT, Half, M10	N220110000
43	WASHER, Spring cross Shaft	1123009009
44	CIRCLIP, Cross Shaft, Galv, Dia 20	F-CIRCL920
45	BUFFER, Rubber	RUBENST02
46	SCREW, Cap, Csk Hd, SS, M4x12	
	COUNTERBALANCE SPRINGS	
47	SPRING, Standard	SPRINGM90
48	SPRING, Heavy Duty	SPRINGR02

Enclosure Assembly

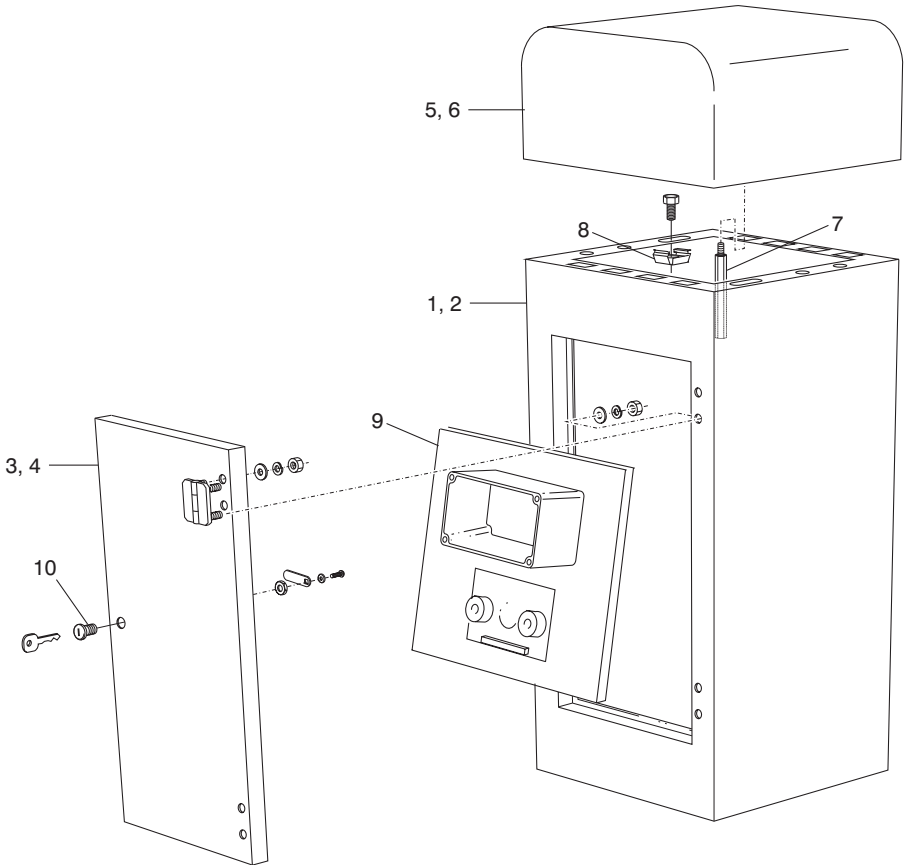

	DESCRIPTION	STOCK CODE
1	BODY, Centor, Mild Steel	1123001000
2	BODY, Centor, Stainless Steel	1123005000
3	DOOR, Centor, Mild Steel	1123002000
4	DOOR, Centor, 430 Stainless Steel	1123006000
5	COVER, Centor, Mild Steel	1123003000
6	COVER, Centor, 430 Stainless Steel	1123007000
7	BOLT, Hex, Centor Cover Tie Down	1123004000
8	NUT, Cage, M8	N-M8CAGE01
9	CHASSIS PLATE ASSEMBLY, Centor	CENTOR-CP1
10	CAMLOCK, Centor	M-B44BCPAT

Wiring Diagram

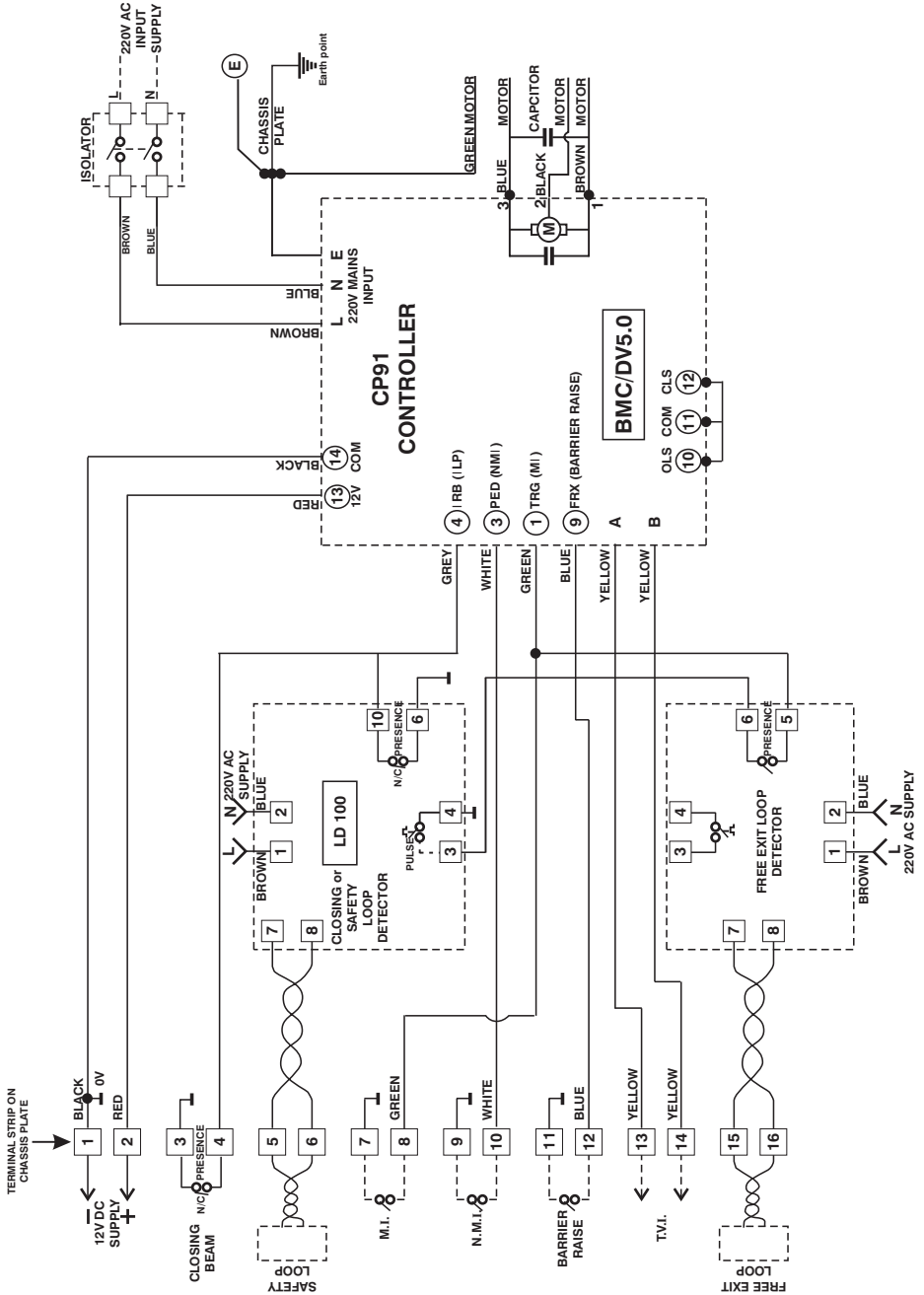

Specifications

MOTOR

Torque Motor Type (MC63-170) 3m; 4.5m
Motor Voltage 220V AC

POWER SUPPLY 230V AC, single phase 50Hz

GENERAL

Standard boom lengths 3,4,5,6m
Boom Cycle time 3 and 4.5m 3 seconds
6m 4 seconds
Duty Continuous

ENCLOSURE

Material 1.6mm mild steel or Grade 430 stainless steel
Surface Finish White epoxy power coat, red cover
Access Door Lockable, hinged. Surface coating as per main enclosure

CONTROLLER

Type Centurion CP91
Trigger Inputs Memory Input for pushbutton, keyswitch, radio control, card reader, keypad and any device with potential free N/O output.
Non-memory input for ticket vendor or cash register.
Inductive Loop Input or IR Beam Input Simplex: Provides safety input
Complex: Boom lowers automatically when loop is cleared.
Auto-Close Simplex: Adjustable between 8 - 35 seconds
Complex: Fixed 90 seconds, not selectable
Interlocks Tickets vend interlock via potential free contact to inhibit ticket issue when boom is raising or up.
Terminals Screw in terminals for auxiliaries and power connection.

Glossary of Terms

Anti Passback

Protection on card readers to prevent the same card from being passed back from one vehicle to the one following. The card reader has a memory which will only allow the card to be used for re-entry once the card has first been used to exit the same site.

Auto-Close

If selected the electronic controller will cause the boom arm to reclose after a present time.

Closing Loop

An inductive loop which sends a signal to the electronic controller signalling that the vehicle is clear of the area and that the arm can close.

Firmware

The instruction set (or code) contained in the microprocessor which controls the actions and responses of the electronic controller.

Free Exit Loop

An inductive loop provided for the purpose of automatically opening a barrier to allow a vehicle to exit.

Inductive Loop Detector

An electronic device which is able to detect a change in inductance of a wire loop due to the presence of a metallic object being placed in the vicinity of the loop.

IR Beam

An infra red beam of light across a driveway. An object breaking the beam causes a relay contact to open (or close) indicating an obstruction.

Loop

A wire loop in the ground connected to an electronic, inductive loop detector to sense the presence of a metallic object (eg. a vehicle)

Memory Input

Electronic controller input which memorises the number of pulses received (eg. from a card reader). The arm will only close after the same number of "exit" pulses have been received (eg. from a closing loop)

Non Memory Input

Electronic controller input which will store only one single pulse in memory irrespective of the number of the pulses received. The boom arm must be closing or closed before the next pulse will take effect.

Presence Loop

An inductive loop used to provide an identification to, for example, a ticket spitter that a vehicle is present and that a ticket can be issued. Also often used to "arm" a card reader, such that the card reader will only accept a valid card when a vehicle is present. (To prevent a pedestrian opening a barrier with a card without a vehicle present.)

Ticket Spitter

A machine capable of issuing a ticket when signalled to do so.

Ticket Vending Interlock

A relay contact connected to a ticket vending machine to prevent tickets being issued while the boom arm is opening or open.



CENTURION

THE AUTOMATIC CHOICE



CENTURION SYSTEMS (PTY) LTD HEAD OFFICE:
TEL: +27 (0)11 699-2400, FAX: +27 (0)11 704-3412 or 462-6669
148 EPSOM AVENUE, NORTH RIDING
P.O. BOX 506, CRAMERVIEW, 2060
SOUTH AFRICA

WEB: <http://www.centsys.co.za> General information e-mail: info@centsys.co.za

FOR TECHNICAL SUPPORT CONTACT:

SOUTH AFRICA

EAST RAND	(011) 397-6401	PORT ELIZABETH	(041) 581-6994/5
DURBAN	(031) 701-9583	EAST LONDON	(043) 743-4923
NELSPRUIT	(013) 752-8074/5	BLOEMFONTEIN	(051) 448-1714
PRETORIA	(012) 349-1745	KIMBERLEY	(053) 832-3231
CAPE TOWN	(021) 447-1295	VEREENIGING	(016) 422-5667

AFRICA

ECHO-LINE, NAMIBIA	Tel: (61) 220-8309
MOLECULAR CONSULTANTS, NIGERIA	Tel: 803-3123182
SECURITY DISTRIBUTORS, ZIMBABWE	Tel: (4) 795-873
SEKANYOLYA TIMBER WORKS, UGANDA	Tel: (41) 231-40

EUROPE

AUTOMATISME BATIMENT, FRANCE	Tel: (1) 697-93120
CROWN AXCESS LTD U.K. UNITED KINGDOM	Tel: (1483) 450-011
NESTOR, BELGIUM	Tel: (9) 380-4020

NORTH AMERICA

BILLY GATES, CANADA	Tel: (250) 334-1553
-------------------------------	---------------------

AUSTRALASIA

ABA GATES, WESTERN AUSTRALIA	Tel: (8) 933-03061
DOMINATOR SYSTEMS, NEW ZEALAND	Tel: (3) 384-5145
ICBT, VICTORIA	Tel: (3) 933-54213
ROTECH, QUEENSLAND	Tel: (7) 326-47330
SA GATES, SOUTHERN AUSTRALIA	Tel: (8) 826-64235
SECURITE DU PACIFIQUE, NEW CALEDONIA	Tel: 283-760

INDIAN OCEAN

SECULOGIX LTD, MAURITIUS	Tel: 467-8509
SECURITE AUTOMATISMES REUNION, REUNION	Tel: 280-368

ASIA & PACIFIC

VAST VIDEO, MALAYSIA	Tel: (3) 214-34931
BLT ASSOCIATES, THAILAND	Tel: (2) 691-6793